

Volvo Construction Equipment  
Building Tomorrow



# EC250E HYBRID

Volvo Excavators





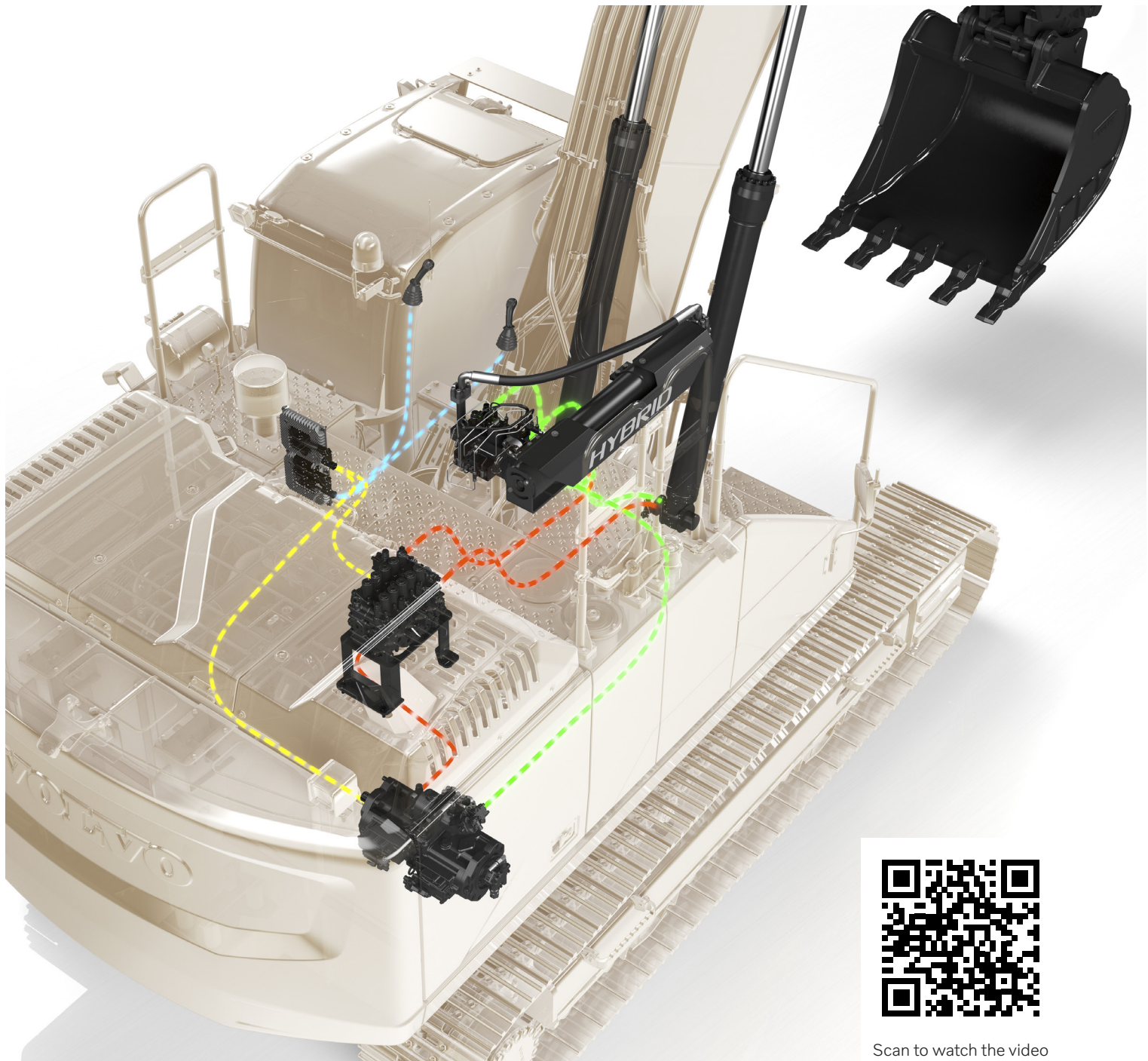

Scan to watch the video

# Simple solution, big savings

Introducing the new EC250E Hybrid. Featuring unique hydraulic hybrid Volvo technology, the excavator utilizes the boom down motion to charge the accumulator, with the stored energy used to drive the assist motor, which powers the engine system.

The result is up to 15%\* increase in fuel efficiency while delivering all the power and performance you would expect from a conventional EC250E.

\*Efficiency and savings may vary based on operator, application and conditions.



**17%**  
greater fuel  
efficiency\*



**15%**  
lower fuel  
consumption\*

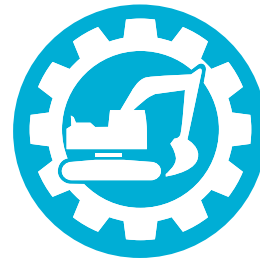

**100%**  
Volvo engineered  
hydraulic hybrid

### Simply reliable

The uncomplicated and reliable hybrid solution is easy to maintain and consists of just a handful of add-on components, meaning no disruption or complication to how the high performing EC250E is engineered.



### Cleaner and greener

The EC250E Hybrid reduces CO<sub>2</sub> emissions by up to 15%\* making it a more environmentally respectful choice, especially when working in built-up areas.

### Rapid payback

When working in dig and dump applications, the EC250E Hybrid is a straightforward solution with fast payback. Save fuel, lower emissions and boost the profitability of your operation.



# EC250E Hybrid in detail

## Engine

The next-generation Volvo diesel engine uses Volvo Advanced Combustion Technology (V-ACT) to deliver lower emissions, superior performance and fuel efficiency. The engine uses precise, highpressure fuel injectors, turbo charger and intercooler, and electronic engine controls to optimize machine performance.

Engine	Volvo	D8M
Max power at	r/min (r/s)	1,600 (26.7)
Net, ISO 9249/SAE J1349	kW (hp)	167 (224)
Gross, ISO 14396/SAE J1995	kW (hp)	168 (225)
Max torque	Nm (ft lbf)	1,166 (859.9)
at engine speed	r/min (r/s)	1,350 (22.5)
No. of cylinders		6
Displacement	l (in <sup>3</sup> )	7.7 (469.9)
Bore	mm (in)	110 (4.3)
Stroke	mm (in)	135 (5.3)

## Hybrid

The uncomplicated and reliable hybrid solution, Volvo's novel hydraulic hybrid harvests 'free' energy generated by the down motion of the excavator's boom and uses it to supercharge the engine system. The powerful and regular boom-down motions charge the 20 litre hydraulic accumulator (5.3 gallon), which then delivers energy to drive the hydraulic assist motor that helps to power the engine system. There are the same levels of controllability and performance as the standard EC250E, including the ability to work in ECO mode and Hybrid mode simultaneously.

## Accumulator

No. of accumulator		1
Displacement	l (gal)	20 (5.3)

## Electrical System

High-capacity electrical system that is well protected. Waterproof double-lock harness plugs are used to secure corrosion-free connections. The main relays and solenoid valves are shielded to prevent damage. The master switch is standard.

Voltage	V	24
Batteries	V	2 x 12
Battery capacity	Ah	170
Alternator	V/A	28 / 80
Start motor	V - kW	24 - 5.5

## Undercarriage

The undercarriage has a robust X-shaped frame. Greased and sealed track chains are standard.

Track shoes		2 x 51
Link pitch	mm (in)	190 (7.5)
Shoe width	mm (in)	600 / 700 / 800 / 900 (23.6 / 27.6 / 31.5 / 35.4)
Shoe width, triple grouser	mm (in)	600 / 700 / 800 / 900 (23.6 / 27.6 / 31.5 / 35.4)
Shoe width, triple grouser (HD)	mm (in)	600 (23.6)
Shoe width, double grouser	mm (in)	600 / 700 (23.6 / 27.6)
Bottom rollers		2 x 9
Top rollers		2 x 2

## Cab

The operator's cab has easy access via a wide door opening. The cab is supported on hydraulic dampening mounts to reduce shock and vibration levels. These along with sound absorbing lining provide low noise levels. The cab has excellent all-round visibility. The front windshield can easily slide up into the ceiling, and the lower front glass can be removed and stored in the side door.

Refrigerant of the type R134a is used when this machine is equipped with air conditioning. Contains fluorinated greenhouse gas R134a, Global Warming Potential 1.430 t CO<sub>2</sub>-eq.

## Swing system

The swing system uses an axial piston motors, driving a planetary gearbox for maximum torque. An automatic holding brake and anti-rebound valve are standard.

Max. slew speed	r/min	11.7
Max. slew torque	kNm (ft lbf)	91.7 (67,634.3)

## Travel System

Each track is powered by an automatic two-speed shift travel motor. The track brakes are multi-disc, spring-applied and hydraulic released. The travel motor, brake and planetary gears are well protected within the track frame.

Max. drawbar pull	kN (lbf)	217 (48,783.5)
Max. travel speed (low)	km/h (mi/h)	3.5 (2.2)
Max. travel speed (high)	km/h (mi/h)	5.5 (3.4)
Gradeability	°	35

## Sound Level

Sound pressure level in cab according to ISO 6396		
L <sub>pA</sub>	dB	70
External sound level according to ISO 6395 and EU Noise Directive 2000/14/EC		
L <sub>WA</sub>	dB	104

### Hydraulic system

The hydraulic system, also known as the "Automatic Sensing Work Mode," is designed for high-productivity, high-digging capacity, high-maneuvering precision and excellent fuel economy. The summation system, boom, arm and swing priority along with boom, arm and bucket regeneration provides optimum performance.

#### Main pump, Type 2 x Variable displacement axial piston pumps

Maximum flow	l/min (gal/min)	2 x 240 (2 x 63.4)
--------------	-----------------	--------------------

#### Pilot pump, Type Gear Pump

Maximum flow	l/min (gal/min)	20.3 (5.4)
--------------	-----------------	------------

#### Relief value setting pressure

Implement	MPa (psi)	33.3 / 36.3 (4,830 / 5,265)
Travel circuit	MPa (psi)	36.3 (5,264.9)
Slew circuit	MPa (psi)	27.9 (4,046.6)
Pilot circuit	MPa (psi)	3.9 (565.6)

### Hydraulic Motors

**Travel:** Variable displacement axial piston motor with mechanical brake

**Swing:** Fixed displacement piston motor with mechanical brake

### Hydraulic Cylinders

Mono boom		2
Bore x Stroke	ø x mm (ø x in)	135 x 1 345 (5.3 x 53)
Arm		1
Bore x Stroke	ø x mm (ø x in)	140 x 1 665 (5.5 x 65.6)
Bucket		1
Bore x Stroke	ø x mm (ø x in)	130 x 1 150 (5.1 x 45.3)

### Service Refill

Fuel tank	l (gal)	472 (124.7)
DEF/AdBlue® tank	l (gal)	50 (13.2)
Hydraulic system, total	l (gal)	385 (101.7)
Hydraulic tank	l (gal)	215 (56.8)
Engine oil	l (gal)	30 (7.9)
Engine coolant	l (gal)	44 (11.6)
Slew reduction unit	l (gal)	5.9 (1.6)
Travel reduction unit	l (gal)	2 x 5 (2 x 1.3)

# Specifications

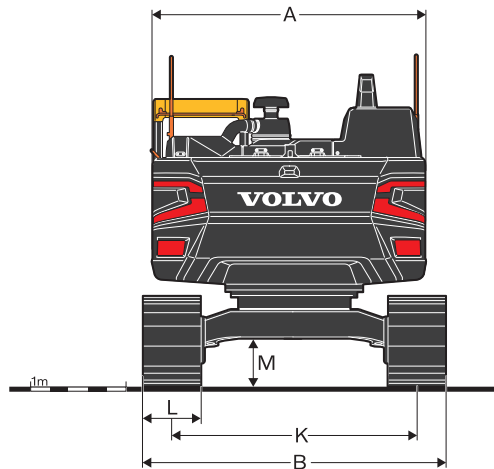
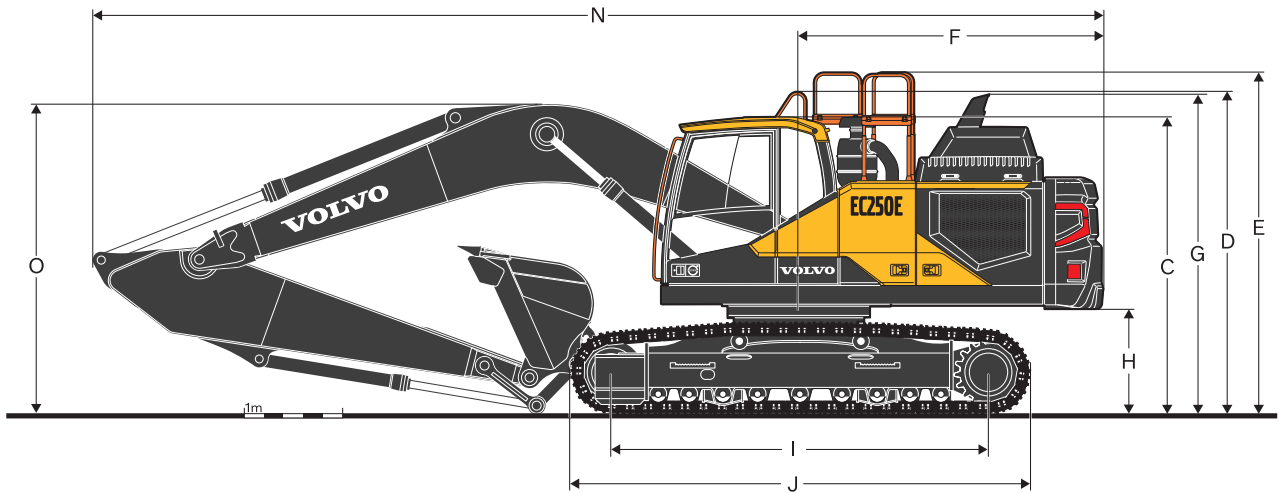

Description	Unit		EC250EL Hybrid					
	m, ft in		6.0, 19'8"					
Boom								
Arm	m	ft in	2.5	8'2"	2.97	9'9"	3.6	11'10"
A. Overall width of upper structure	mm	ft in	2,890	9'6"	2,890	9'6"	2,890	9'6"
B. Overall width	mm	ft in	3,190	10'6"	3,190	10'6"	3,190	10'6"
C. Overall height of cab	mm	ft in	3,045	9'12"	3,045	9'12"	3,045	9'12"
D. Overall height of handrail	mm	ft in	3,310	10'10"	3,310	10'10"	3,310	10'10"
E. Overall height of guardrail (Unfolded)	mm	ft in	3,515	11'6"	3,515	11'6"	3,515	11'6"
E'. Overall height of handrail/guardrail (Folded)	mm	ft in	3,035	9'11"	3,035	9'11"	3,035	9'11"
F. Tail swing radius	mm	ft in	3,075	10'1"	3,075	10'1"	3,075	10'1"
G. Overall height of diffuser	mm	ft in	3,135	10'3"	3,135	10'3"	3,135	10'3"
H. Counterweight clearance *	mm	ft in	1,045	3'5"	1,045	3'5"	1,045	3'5"
I. Tumbler length	mm	ft in	3,850	12'8"	3,850	12'8"	3,850	12'8"
J. Track length	mm	ft in	4,650	15'3"	4,650	15'3"	4,650	15'3"
K. Track gauge	mm	ft in	2,590	8'6"	2,590	8'6"	2,590	8'6"
L. Shoe width	mm	ft in	600	24"	600	24"	600	24"
M. Min. ground clearance *	mm	ft in	470	1'7"	470	1'7"	470	1'7"
N. Overall length	mm	ft in	10,310	33'10"	10,230	33'7"	10,300	33'10"
O. Overall height of boom	mm	ft in	3,330	10'11"	3,110	10'2"	3,330	10'11"

\* Without shoe grouser

' 2-piece boom

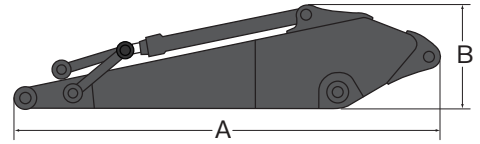
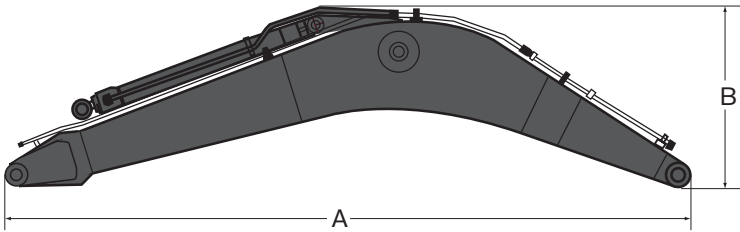

**DIMENSIONS**

Description	Unit		mono			
			6.0, 19'8" GP		6.0, 19'8" HD	
Boom	m	ft in				
Length	mm	ft in	6,220	20'5"	6,220	20'5"
Height	mm	ft in	1,750	5'9"	1,750	5'9"
Width	mm	ft in	725	2'5"	725	2'5"
Weight	kg	lb	2,230	4,920	2,355	5,190

\* Includes cylinder, piping and pin, excludes boom cylinder pin

Description	Unit									
			2.5, 8'2" HD		2.97, 9'9" GP		2.97, 9'9" HD		3.6, 11'10" GP	
Arm	m	ft in								
Length	mm	ft in	3,580	11'9"	4,050	13'3"	4,050	13'3"	4,715	15'6"
Height	mm	ft in	995	3'3"	995	3'3"	995	3'3"	1,000	3'3"
Width	mm	ft in	510	1'8"	510	1'8"	510	1'8"	510	1'8"
Weight	kg	lb	1,210	2,670	1,245	2,750	1,300	2,870	1,335	2,940

\* Includes cylinder, linkage and pin

# Specifications

<b>WORKING RANGES</b>										
<b>Description</b>		<b>Unit</b>		<b>EC250EL Hybrid</b>						
<b>Boom</b>		<b>m, ft in</b>		<b>6.0, 19'8"</b>						
<b>Arm</b>		<b>m</b>	<b>ft in</b>	<b>2.5</b>	<b>8'2"</b>	<b>2.97</b>	<b>9'9"</b>	<b>3.6</b>	<b>11'10"</b>	
A. Max. digging reach		mm	ft in	9,960	32'8"	10,340	33'11"	10,810	35'6"	
B. Max. digging reach on ground		mm	ft in	9,775	32'1"	10,160	33'4"	10,640	34'11"	
C. Max. digging depth		mm	ft in	6,590	21'7"	7,060	23'2"	7,690	25'3"	
D. Max. digging depth (l = 2.44 m / 8'0" level)		mm	ft in	6,375	20'11"	6,855	22'6"	7,470	24'6"	
E. Max. vertical wall digging depth		mm	ft in	5,265	17'3"	5,520	18'1"	5,805	19'1"	
F. Max. cutting height		mm	ft in	9,620	31'7"	9,685	31'9"	9,645	31'8"	
G. Max. dumping height		mm	ft in	6,610	21'8"	6,710	22'0"	6,730	22'1"	
H. Min. front swing radius		mm	ft in	3,915	12'10"	3,890	12'9"	3 890	12'9"	
<b>DIGGING FORCES WITH DIRECT FIT BUCKET</b>										
Bucket radius		mm	ft	1,620	64"	1,620	64"	1,620	64"	
Breakout force	Normal	SAE J1179	kN	lbf	145	32,490	145	32,510	145	32,500
	Power boost		kN	lbf	157	35,350	157	35,370	157	35,370
	Normal	ISO 6015	kN	lbf	166	37,390	166	37,410	166	37,400
	Power boost		kN	lbf	181	40,690	181	40,710	181	40,710
Tearout force	Normal	SAE J1179	kN	lbf	132	29,620	114	25,650	102	22,960
	Power boost		kN	lbf	143	32,240	124	27,910	111	24,980
	Normal	ISO 6015	kN	lbf	136	30,650	118	26,410	105	23,530
	Power boost		kN	lbf	148	33,360	128	28,740	114	25,610
Rotation angle, bucket			°		177		177		177	



**MACHINE WITH MONO BOOM**

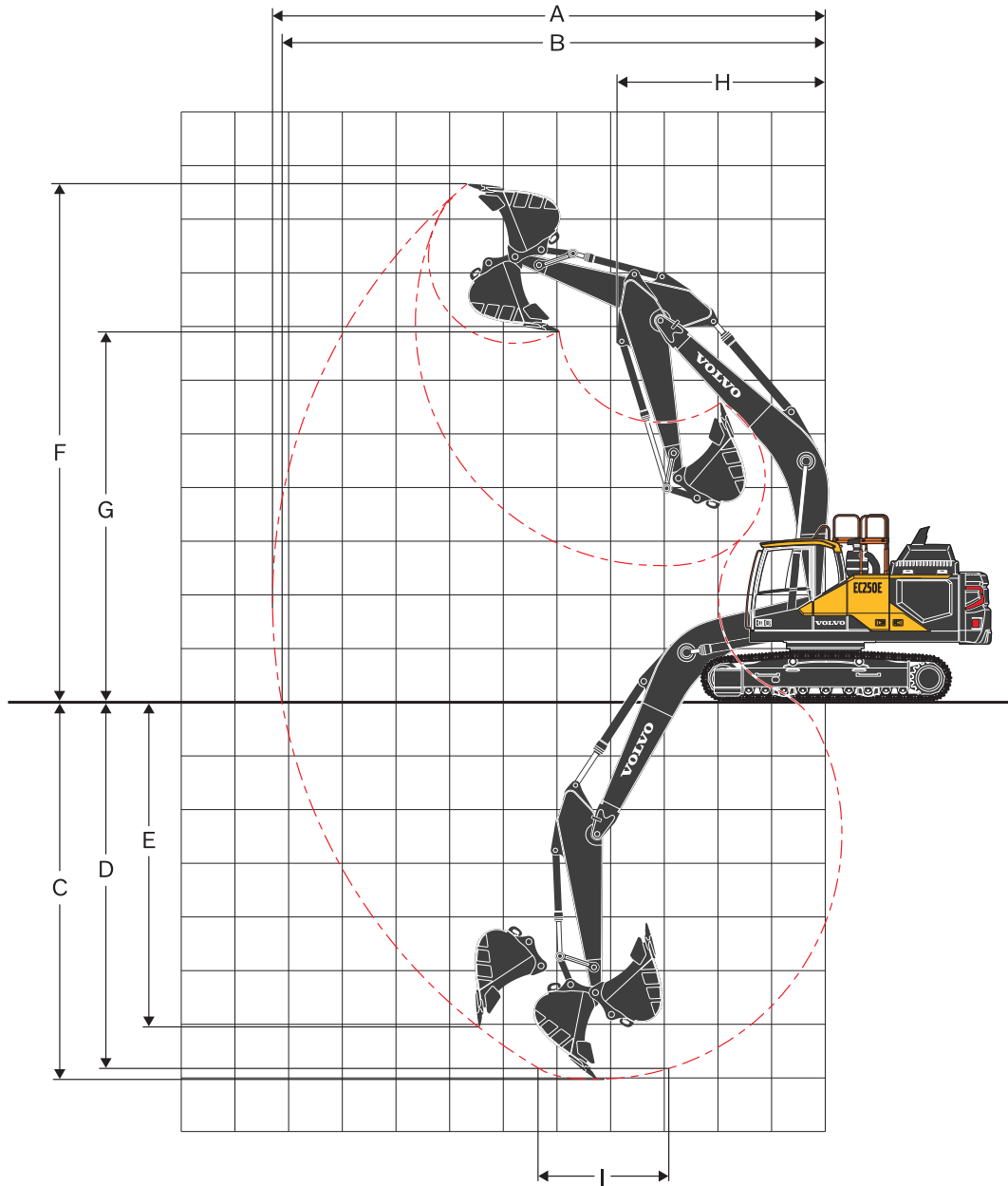

# Specifications

## MACHINE WEIGHTS AND GROUND PRESSURE

### EC250EL Hybrid

Description	Shoe width		Operating weight		Ground pressure		Overall width			
	mm	in	kg	lb	kPa	psi	mm	in		
			<b>6.0 m (19'8") boom (GP), 2.97 m (9'9") arm (GP), 1,200 kg (2,650 lb) / 1.14 m<sup>3</sup> (301 gal) bucket, 4,950 kg (10,910 lb) counterweight</b>							
<b>Triple grouser</b>	600	24	27,230	60,040	53.8	7.8	3,190	10'6"		
	600 (HD)	24	27,470	60,570	54.3	7.9	3,190	10'6"		
	700	28	27,530	60,700	46.6	6.8	3,290	10'10"		
	800	31	27,820	61,340	41.2	6.0	3,390	11'1"		
	900	35	28,130	62,030	37.0	5.4	3,490	11'5"		
<b>Double grouser</b>	600	24	27,450	60,530	54.2	7.9	3,190	10'6"		
	700	28	27,790	61,280	47.1	6.8	3,290	10'10"		
			<b>6.0 m (19'8") boom (HD), 2.97 m (9'9") arm (HD), 1,200 kg (2,650 lb) / 1.14 m<sup>3</sup> (301 gal) bucket, 4,950 kg (10,910 lb) counterweight</b>							
<b>Triple grouser</b>	600	24	27,410	60,440	54.1	7.8	3,190	10'6"		
	600 (HD)	24	27,650	60,970	54.6	7.9	3,190	10'6"		
	700	28	27,710	61,100	46.9	6.8	3,290	10'10"		
	800	31	28,000	61,740	41.5	6.0	3,390	11'1"		
	900	35	28,310	62,420	37.3	5.4	3,490	11'5"		
<b>Double grouser</b>	600	24	27,630	60,920	54.6	7.9	3,190	10'6"		
	700	28	27,970	61,670	47.4	6.9	3,290	10'10"		

**BUCKET SELECTION GUIDE**

Bucket type		Capacity		Cutting width		Weight		Teeth	EC250EL Hybrid		
									600 mm (24") shoe, 4,950 kg (10,910 lb) counterweight		
		6.0 m (19'8") GP Boom									
		L	yd <sup>3</sup>	mm	in	kg	lb	EA	2.5 m (8'2") Arm	2.97 m (9'9") Arm	3.6 m (11'10") Arm
Direct fit bucket	General purpose	560	0.73	600	23.6	800	1,763	3	C	C	C
		620	0.81	750	29.5	823	1,814	3	C	C	C
		770	1.01	900	35.4	983	2,167	4	C	C	C
		950	1.24	1,090	42.9	1,012	2,231	4	C	C	C
		1,140	1.49	1,240	48.8	1,179	2,600	5	C	C	C
		1,320	1.73	1,390	54.7	1,196	2,636	5	C	C	C
		1,450	1.90	1,490	58.7	1,249	2,754	5	C	C	C
		1,510	1.98	1,540	60.6	1,294	2,854	5	C	C	C
	1,760	2.30	1,740	68.5	1,435	3,163	6	C	B	B	
	Heavy duty	560	0.73	600	23.6	870	1,917	3	D	D	D
		620	0.81	750	29.5	880	1,941	3	D	D	D
		1,140	1.49	1,240	48.8	1,200	2,646	5	D	D	D
		1,320	1.73	1,390	54.7	1,289	2,843	5	D	D	D
		1,510	1.98	1,540	60.6	1,377	3,035	5	D	D	C
1,760		2.30	1,740	68.5	1,533	3,380	6	C	B	A	
Direct fit bucket (UQC interface)	General purpose	560	0.73	600	23.6	800	1,763	3	C	C	C
		620	0.81	750	29.5	823	1,814	3	C	C	C
		770	1.01	900	35.4	983	2,167	4	C	C	C
		950	1.24	1,090	42.9	1,012	2,231	4	C	C	C
		1,140	1.49	1,240	48.8	1,179	2,600	5	C	C	C
		1,320	1.73	1,390	54.7	1,196	2,636	5	C	C	C
		1,450	1.90	1,490	58.7	1,249	2,754	5	C	C	B
		1,510	1.98	1,540	60.6	1,294	2,854	5	C	B	A
	1,760	2.30	1,740	68.5	1,435	3,163	6	B	A	X	
	Heavy duty	560	0.73	600	23.6	870	1,917	3	D	D	D
		620	0.81	750	29.5	880	1,941	3	D	D	D
		1,140	1.49	1,240	48.8	1,200	2,646	5	D	D	D
		1,320	1.73	1,390	54.7	1,289	2,843	5	D	C	B
		1,510	1.98	1,540	60.6	1,377	3,035	5	C	B	A
1,760		2.30	1,740	68.5	1,533	3,380	6	B	A	X	

Please consult with your Volvo dealer for the proper match of buckets and attachments to suit the application. The recommendations are given as a guide only, based on typical operation conditions. Bucket capacity based on ISO 7451, heaped material with a 1:1 angle of repose.

Maximum material density			
	kg/m <sup>3</sup>	lb/yd <sup>3</sup>	
A	1,200~1,300	2,000~2,200	Coal, Caliche, Shale
B	1,400~1,600	2,300~2,700	Wet earth and clay, Limestone, Sandstone
C	1,700~1,800	2,800~3,100	Granite, Wet sand, Well blasted rock
D	> 1,900	> 3,200	Wet mud, Iron ore
X	Not recommended		



# Specifications

## LIFTING CAPACITY EC250EL Hybrid

Lifting capacity at the arm end without bucket.

For lifting capacity including bucket, simply subtract actual weight of the direct fit bucket or the bucket with quick coupler from the following values.

	Lifting Point	1.5 m, 5 ft		3.0 m, 10 ft		4.5 m, 15 ft		6.0 m, 20 ft		7.5 m, 25 ft		9.0 m, 30 ft		Max. Reach		
		Along UC	Across UC	Along UC	Across UC	Along UC	Across UC	Along UC	Across UC	Along UC	Across UC	Along UC	Across UC	Along UC	Across UC	Max.
<b>Boom :</b> 6.0 m, 19'8" <b>Arm :</b> 2.5 m, 8'2" <b>Shoe :</b> 600 mm, 24" <b>CWT :</b> 4,950 kg, 10,910 lb	7.5 m kg							*6,890	*6,890					*6,940	*6,940	6.10 m
	25 ft lb													*15,010	*15,010	19.69 ft
	6.0 m kg							*6,900	*6,900					*6,930	5,540	7.22 m
	20 ft lb							*14,800	*14,800					*14,970	11,970	23.55 ft
	4.5 m kg					*9,320	*9,320	*7,740	7,250	*7,100	5,140			6,960	4,720	7.90 m
	15 ft lb					*19,650	*19,650	*16,490	15,190	*15,280	10,700			15,030	10,100	25.88 ft
	3.0 m kg					*12,020	10,510	*8,950	6,930	7,430	5,000			6,400	4,320	8.25 m
	10 ft lb					*25,390	22,000	*19,040	14,480	15,600	10,410			13,750	9,200	27.09 ft
	1.5 m kg					*14,100	9,930	*10,090	6,630	7,270	4,850			6,230	4,180	8.32 m
	5 ft lb					*30,000	20,730	21,360	13,830	15,260	10,100			13,360	8,880	27.33 ft
	0 m kg					*14,870	9,960	9,960	6,440	7,150	4,750			6,400	4,270	8.11 m
	0 ft lb					*31,820	20,220	20,900	13,430	15,020	9,890			13,730	9,080	26.63 ft
	-1.5 m kg			*10,440	*10,440	*14,660	9,650	9,880	6,370	7,120	4,720			7,000	4,650	7.59 m
	-5 ft lb			*23,830	*23,830	*31,460	20,180	20,770	13,310					15,100	9,930	24.90 ft
	-3.0 m kg			*18,690	*18,690	*13,560	9,750	9,940	6,430					8,450	5,550	6.70 m
-10 ft lb			*40,270	*40,270	*29,060	20,460	20,980	13,500					18,390	11,990	21.90 ft	
-4.5 m kg			*14,940	*14,940	*10,900	10,030							*9,080	8,030	5.24 m	
-15 ft lb			*31,840	*31,840	*23,020	21,200							*19,820	17,790	16.94 ft	
<b>Boom :</b> 6.0 m, 19'8" <b>Arm :</b> 2.97 m, 9'9" <b>Shoe :</b> 600 mm, 24" <b>CWT :</b> 4,950 kg, 10,910 lb	7.5 m kg													*6,080	*6,080	6.61 m
	25 ft lb							*13,350	*13,350					*13,460	*13,460	21.40 ft
	6.0 m kg							*6,330	*6,330	*6,390	5,300			*5,830	5,120	7.66 m
	20 ft lb							*13,590	*13,590					*12,820	11,070	24.99 ft
	4.5 m kg					*8,430	*8,430	*7,220	*7,220	*6,670	5,210			*5,860	4,420	8.30 m
	15 ft lb					*17,840	*17,840	*15,420	*15,420	*14,370	10,900			*12,840	9,490	27.20 ft
	3.0 m kg					*11,140	10,720	*8,490	7,020	*7,280	5,050			6,010	4,070	8.64 m
	10 ft lb					*23,630	22,550	*18,110	14,730	*15,620	10,570			12,950	8,690	28.35 ft
	1.5 m kg					*13,500	10,070	*9,740	6,700	7,300	4,890			5,850	3,940	8.70 m
	5 ft lb					*28,800	21,120	*20,820	14,030	15,380	10,220			12,590	8,400	28.58 ft
	0 m kg			*5,020	*5,020	*14,680	9,730	9,990	6,470	7,160	4,760			5,980	4,000	8.50 m
	0 ft lb			*11,570	*11,570	*31,500	20,410	21,040	13,560	15,090	9,950			12,880	8,550	27.91 ft
	-1.5 m kg	*6,670	*6,670	*10,700	*10,700	*14,820	9,620	9,860	6,360	7,090	4,690			6,470	4,310	8.01 m
	-5 ft lb	*14,880	*14,880	*24,230	*24,230	*31,870	20,220	20,810	13,350	14,980	9,850			13,990	9,240	26.26 ft
	-3.0 m kg	*12,360	*12,360	*17,780	*17,780	*14,040	9,670	9,880	6,370					7,610	5,020	7.17 m
-10 ft lb	*27,720	*27,720	*40,420	*40,420	*30,210	20,390	20,890	13,430					16,570	10,870	23.44 ft	
-4.5 m kg			*16,720	*16,720	*12,000	9,880							*8,940	6,810	5.83 m	
-15 ft lb			*35,860	*35,860	*25,620	20,940							*19,620	15,020	18.90 ft	
<b>Boom :</b> 6.0 m, 19'8" <b>Arm :</b> 3.6 m, 11'10" <b>Shoe :</b> 600 mm, 24" <b>CWT :</b> 4,950 kg, 10,910 lb	7.5 m kg													*5,040	*5,040	7.23 m
	25 ft lb													*11,110	*11,110	23.43 ft
	6.0 m kg									*5,650	5,400			*4,900	4,640	8.19 m
	20 ft lb									*12,170	11,240			*10,740	9,990	26.75 ft
	4.5 m kg							*6,430	*6,430	*6,060	5,270			*4,950	4,060	8.80 m
	15 ft lb							*13,660	*13,660	*12,970	10,990			*10,830	8,660	28.82 ft
	3.0 m kg			*15,760	*15,760	*9,850	*9,850	*7,750	7,110	*6,750	5,090	*5,650	3,830	*5,180	3,750	9.11 m
	10 ft lb			*32,940	*32,940	*20,800	*20,800	*16,460	14,870	*14,410	10,590			*11,320	7,960	29.91 ft
	1.5 m kg					*12,490	10,210	*9,130	6,740	7,320	4,890	5,560	3,730	5,400	3,630	9.17 m
	5 ft lb					*26,510	21,330	*19,420	14,060	15,350	10,170	11,630	7,720	11,560	7,670	30.12 ft
	0 m kg			*7,080	*7,080	*14,150	9,740	9,990	6,460	7,140	4,730			5,490	3,660	8.98 m
	0 ft lb			*16,080	*16,080	*30,200	20,300	20,960	13,450	14,970	9,820			11,750	7,760	29.49 ft
	-1.5 m kg	*6,800	*6,800	*10,800	*10,800	*14,740	9,540	9,810	6,300	7,030	4,630			5,870	3,900	8.52 m
	-5 ft lb	*15,140	*15,140	*24,400	*24,400	*31,560	19,890	20,590	13,120	14,760	9,630			12,610	8,280	27.94 ft
	-3.0 m kg	*11,030	*11,030	*16,000	*16,000	*14,400	9,520	9,760	6,260	7,020	4,620			6,730	4,440	7.74 m
-10 ft lb	*24,690	*24,690	*36,250	*36,250	*30,860	19,920	20,540	13,090	14,800	9,660			14,550	9,510	25.31 ft	
-4.5 m kg	*16,340	*16,340	*18,580	*18,580	*12,990	9,660	*9,600	6,360					*8,610	5,690	6.52 m	
-15 ft lb	*36,820	*36,820	*39,780	*39,780	*27,730	20,320	*20,340	13,380					*18,820	12,390	21.18 ft	
-6.0 m kg					*9,450	*9,450							*9,390	*9,390	4.52 m	
-20 ft lb					*20,834	*20,834							*20,701	*20,701	14.83 ft	

Notes: 1. Machine in "Fine Mode-F" (Power Boost) for lifting capacities. 2. The above loads are in compliance with SAE J1097 and ISO 10567 Hydraulic Excavator Lifting Capacity Standards. 3. Rated loads do not exceed 87% of hydraulic lifting capacity or 75% of tipping load. 4. Rated loads marked with an asterisk (\*) are limited by hydraulic capacity rather than tipping load.

**LIFTING CAPACITY EC250EL Hybrid**

Lifting capacity at the arm end without bucket.

For lifting capacity including bucket, simply subtract actual weight of the direct fit bucket or the bucket with quick coupler from the following values.

	Lifting Point	1.5 m, 5 ft		3.0 m, 10 ft		4.5 m, 15 ft		6.0 m, 20 ft		7.5 m, 25 ft		9.0 m, 30 ft		Max. Reach			
		Along UC	Across UC	Along UC	Across UC	Along UC	Across UC	Along UC	Across UC	Along UC	Across UC	Along UC	Across UC	Along UC	Across UC	Max.	
Boom : 6.0 m, 19'8" Arm : 2.5 m, 8'2" Shoe : 800 mm, 32" CWT : 4,950 kg, 10,910 lb	7.5 m kg							*6,880	*6,880					*6,930	*6,930	6.10 m	
	25 ft lb													*14,960	*14,960	19.69 ft	
	6.0 m kg							*6,890	*6,890					*6,910	5,640	7.22 m	
	20 ft lb							*14,740	*14,740					*14,900	12,180	23.55 ft	
	4.5 m kg							*9,310	*9,310	*7,730	7,390	*7,070	5,240		*7,040	4,810	7.90 m
	15 ft lb							*19,580	*19,580	*16,420	15,450	*15,200	10,880		*15,190	10,270	25.88 ft
	3.0 m kg							*11,980	10,690	*8,920	7,050	7,580	5,090		6,530	4,400	8.25 m
	10 ft lb							*25,270	22,350	*18,940	14,710	15,910	10,580		14,020	9,340	27.09 ft
	1.5 m kg							*14,050	10,090	*10,050	6,750	7,410	4,940		6,350	4,250	8.32 m
	5 ft lb							*29,840	21,040	*21,380	14,050	15,550	10,260		13,620	9,020	27.33 ft
	0 m kg							*14,800	9,840	10,150	6,550	7,290	4,830		6,520	4,340	8.11 m
	0 ft lb							*31,640	20,510	21,300	13,630	15,310	10,040		14,000	9,220	26.63 ft
	-1.5 m kg				*10,440	*10,440	*14,590	9,790	10,060	6,470	7,250	4,790			7,130	4,720	7.59 m
	-5 ft lb				*23,830	*23,830	*31,270	20,470	21,160	13,500					15,380	10,080	24.90 ft
	-3.0 m kg				*18,580	*18,580	*13,480	9,890	*10,090	6,520					8,610	5,640	6.70 m
-10 ft lb				*40,020	*40,020	*28,890	20,760	21,370	13,700					18,730	12,170	21.90 ft	
-4.5 m kg				*14,840	*14,840	*10,830	10,170							*9,020	8,150	5.24 m	
-15 ft lb				*31,610	*31,610	*22,870	21,520							*19,680	18,060	16.94 ft	
Boom : 6.0 m, 19'8" Arm : 2.97 m, 9'9" Shoe : 800 mm, 32" CWT : 4,950 kg, 10,910 lb	7.5 m kg													*6,050	*6,050	6.61 m	
	25 ft lb							*13,200	*13,200						*13,420	*13,420	21.40 ft
	6.0 m kg							*6,280	*6,280	*6,330	5,370				*5,800	5,180	7.66 m
	20 ft lb							*13,430	*13,430						*12,780	11,170	24.99 ft
	4.5 m kg							*8,390	*8,390	*7,170	*7,170	*6,620	5,280		*5,830	4,470	8.30 m
	15 ft lb							*17,640	*17,640	*15,230	*15,230	*14,170	10,990		*12,800	9,540	27.20 ft
	3.0 m kg							*11,080	10,890	*8,430	7,120	*7,220	5,120		*6,070	4,110	8.64 m
	10 ft lb							*23,340	22,760	*17,870	14,850	*15,410	10,630		13,100	8,720	28.35 ft
	1.5 m kg							*13,410	10,200	*9,660	6,780	7,420	4,940		5,940	3,970	8.70 m
	5 ft lb							*28,440	21,250	*20,540	14,110	15,560	10,260		12,720	8,420	28.58 ft
	0 m kg				*4,990	*4,990	*14,580	9,850	10,150	6,540	7,270	4,810			6,070	4,040	8.50 m
	0 ft lb				*11,530	*11,530	*31,100	20,490	21,280	13,600	15,260	9,980			13,010	8,560	27.91 ft
	-1.5 m kg	*6,640	*6,640	*10,660	*10,660	*14,700	9,740	10,020	6,430	7,200	4,740				6,570	4,350	8.01 m
	-5 ft lb	*14,840	*14,840	*24,190	*24,190	*31,470	20,290	21,040	13,390	15,140	9,870				14,140	9,260	26.26 ft
	-3.0 m kg	*12,320	*12,320	*17,740	*17,740	*13,930	9,780	10,030	6,440						7,720	5,070	7.17 m
-10 ft lb	*27,680	*27,680	*40,400	*40,400	*29,820	20,480	21,130	13,470						16,760	10,900	23.44 ft	
-4.5 m kg			*16,570	*16,570	*11,890	10,000								*8,850	6,880	5.83 m	
-15 ft lb			*35,370	*35,370	*25,260	21,070								*19,330	15,110	18.90 ft	
Boom : 6.0 m, 19'8" Arm : 3.6 m, 11'10" Shoe : 800 mm, 32" CWT : 4,950 kg, 10,910 lb	7.5 m kg													*5,040	*5,040	7.23 m	
	25 ft lb														*11,110	*11,110	23.43 ft
	6.0 m kg										*5,640	5,500			*4,900	4,730	8.19 m
	20 ft lb										*12,120	11,450			*10,740	10,170	26.75 ft
	4.5 m kg									*6,420	*6,420	*6,050	5,380		*4,950	4,140	8.80 m
	15 ft lb									*13,610	*13,610	*12,910	11,190		*10,830	8,810	28.82 ft
	3.0 m kg				*15,730	*15,730	*9,830	*9,830	*7,730	7,250	*6,730	5,190	*5,650	3,900	*5,180	3,820	9.11 m
	10 ft lb				*32,810	*32,810	*20,710	*20,710	*16,390	15,130	*14,330	10,770			*11,320	8,090	29.91 ft
	1.5 m kg						*12,450	10,390	*9,100	6,860	7,470	4,980	5,670	3,800	5,510	3,690	9.17 m
	5 ft lb						*26,380	21,670	*19,320	14,290	15,660	10,340	11,860	7,850	11,790	7,800	30.12 ft
	0 m kg				*7,080	*7,080	*14,100	9,900	*10,160	6,570	7,280	4,810			5,600	3,730	8.98 m
	0 ft lb				*16,080	*16,080	*30,040	20,600	21,360	13,660	15,270	9,980			11,990	7,880	29.49 ft
	-1.5 m kg	*6,800	*6,800	*10,800	*10,800	*14,670	9,690	10,000	6,400	7,170	4,710				5,980	3,960	8.52 m
	-5 ft lb	*15,140	*15,140	*24,400	*24,400	*31,380	20,180	20,980	13,320	15,050	9,780				12,850	8,410	27.94 ft
	-3.0 m kg	*11,030	*11,030	*16,000	*16,000	*14,330	9,670	9,950	6,360	7,160	4,700				6,850	4,510	7.74 m
-10 ft lb	*24,690	*24,690	*36,250	*36,250	*30,680	20,210	20,930	13,280	15,080	9,810				14,830	9,660	25.31 ft	
-4.5 m kg	*16,340	*16,340	*18,470	*18,470	*12,920	9,810	*9,550	6,460						*8,560	5,770	6.52 m	
-15 ft lb	*36,820	*36,820	*39,520	*39,520	*27,560	20,620	*20,210	13,580						*18,700	12,580	21.18 ft	
-6.0 m kg						*9,380	*9,380							*9,330	*9,330	4.52 m	
-20 ft lb						*20,679	*20,679							*20,569	*20,569	14.83 ft	

Notes: 1. Machine in "Fine Mode-F" (Power Boost) for lifting capacities. 2. The above loads are in compliance with SAE J1097 and ISO 10567 Hydraulic Excavator Lifting Capacity Standards. 3. Rated loads do not exceed 87% of hydraulic lifting capacity or 75% of tipping load. 4. Rated loads marked with an asterisk (\*) are limited by hydraulic capacity rather than tipping load.

# Equipment

## STANDARD EQUIPMENT

### Engine

Turbocharged, 4 stroke diesel engine with water cooling, direct injection and charged air cooler that meets Tier 4 final requirements

Air filter with indicator

Air intake heater

Cyclone pre-cleaner

Electric engine shut-off

Fuel filter and water separator

Delayed engine shutdown

Alternator, 80 A

Quick engine oil change system

### Hybrid

Accumulator, 20 l (5.3 gal)

Boom regeneration valves

Assist motor

Main pump with PTO

### Electric / Electronic control system

Advanced mode control system

Self-diagnostic system

Machine status indication

Engine speed sensing power control

Automatic idling system

Onetouch power boost

Safety stop/start function

Adjustable LCD color monitor

Master electrical disconnect switch

Engine restart prevention circuit

High-capacity halogen lights:

- Frame-mounted 2

- Boom-mounted 1

Extra work lights (Halogen):

- Cab-mounted 3

- Boom-mounted 1

Batteries, 2 x 12 V / 170 A

Start motor, 24 V / 5.5 kW

Travel alarm

### Frame

Access way with handrail

Tool storage area

Punched metal anti-slip plates

Counterweight: 4,950 kg (10,910 lb)

### Undercarriage

Undercover (heavy-duty)

Hydraulic track adjusters

Greased and sealed track link

Track Guard

### Hydraulic system

Boom up swing priority function

Boom travel priority function (Creep)

Boom down speed control

Attachment management system (up to 32 programmable memories)

- Variable flow and pressure pre-setting

Hammer & shear, 2 pump flow

Additional return filter (Hammer & shear piping)

Boom float function without HRV

Straight travel pedal

Automatic sensing hydraulic system

- Summation system

- Boom priority

- Arm priority

- Swing priority

ECO mode fuel saving technology

Boom, arm and bucket regeneration valves

Swing anti-rebound valves

Boom and arm holding valves

Multi-stage filtering system

Cylinder cushioning

Cylinder contamination seals

Auxiliary hydraulic valve

Automatic two-speed travel motors

Hydraulic oil, ISO VG 46

Quick coupler piping

Quick hydraulic oil fill connection

## STANDARD EQUIPMENT

### Cab and interior

ROPS (ISO 12117-2) certified cab

Opening top hatch

Silicon oil and rubber mounts with spring

Travel pedals and hand levers

Adjustable operator seat and joystick control console

Heater & air-conditioner, automatic

Flexible antenna

Radio with MP3 & USB Jack with bluetooth

Hydraulic safety lock lever

Cab, all-weather sound suppressed, includes:

- Cup holders

- Door locks

- Tinted glass

- Floor mat

- Horn

- Large storage area

- Pull-up type front window

- Removable lower windshield

- Seat belt

- Safety glass

- Sun screens, front, roof, rear

- Rain shield

- Windshield wiper with intermittent feature

Volvo smart view

Master key

### Track shoes

800 mm (32") with triple grousers

### Digging equipment

Linkage with lifting eye

Boom: 6.0 m (19'8") monoblock

Arm: 2.97 m (9'9")

Manual centralized lubrication

### Machine controls

Dig Assist

Volvo Active Control (Semi-autonomous)

## OPTIONAL EQUIPMENT

### Engine

Block heater: 120 V, 240 V

Oil bath pre-cleaner

Diesel coolant heater, 10 kW

Water separator with heater

Auto engine shutdown

Reversible fan

Fuel filler pump: 13.2 gpm, with automatic shutoff

### Electric

Extra work lights(LED):

- Cab-mounted 3

- Boom-mounted 1

- Counterweight-mounted 1

Green light beacon

Anti-theft system

Rotating warning beacon

Smart connect for tilt rotator

Tilt rotator 3rd gen

Dig assist, smart connect



---

**OPTIONAL EQUIPMENT**

---

**Undercarriage**

Full track guard

Track shoes

600/700/900 mm (24"/28"/36") with triple grousers

600 mm (24") HD with triple grousers

600/700 mm (24"/28") with double grousers

High walker undercarriage

**Hydraulic system**

CDC, Comfort Driving Control

Hose rupture valve: boom &amp; arm

Overload warning device

Boom float function with HRV

Hydraulic piping:

- Slope &amp; rotator

- Grapple

- Oil leak (drain) line

Volvo hydraulic quick coupler S1

Volvo hydraulic quick coupler S2

Volvo hydraulic quick coupler U25

Volvo hydraulic quick coupler SQ70 55

Volvo hydraulic quick coupler SQ70

Hydraulic oil, biodegradable 46

Hydraulic oil, longlife oil 32

Hydraulic oil, longlife oil 46

Fuel tank-fast fuel fill prep

Hammer &amp; shear, 1 pump flow

3 way selection valve

---

**OPTIONAL EQUIPMENT**

---

**Cab and interior**

Fabric seat with heater

Fabric seat with heater and air suspension

Deluxe seat

High-strength one piece front windshield (P5A)

Falling object guard, FOG (fixed type or hinge type)

Frame-mounted

Cab-mounted

Cab-mounted falling object protective structure (FOPS)

Side view camera

Smoker kit (ashtray and lighter)

Safety net for front window

Lower wiper with intermittent control

Anti-vandalism kit

Air pressure supply in cabin

Rear view camera

Control joysticks with 4 switches

Proportional joysticks with 3 switches

**Digging equipment**

Boom: 6.0 m (19'8") monoblock, heavy duty

Arm: 2.5 m (8'2") HD, 2.97 m (9'9") HD, 3.6 m (11'10")

**Service**

Tool kit, daily maintenance

Tool kit, full scale

Automatic lubrication system

---

**SELECTION OF VOLVO OPTIONAL EQUIPMENT**

---

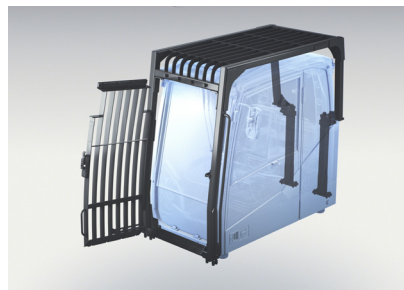
**Deluxe seat****Reversible cooling fan****TiltRotator****Oil drain line****Swing out FOG**

Not all products are available in all markets. Under our policy of continuous improvement, we reserve the right to change specifications and design without prior notice. The illustrations do not necessarily show the standard version of the machine.

**VOLVO**

**Volvo Construction Equipment**

[volvoce.com](http://volvoce.com)