



Volvo Articulated Haulers
Imperial: 60.6 ton(us) / 121,254lb / 630HP
Metric: 55t / 55,000kg / 470kW

A60H

Volvo Construction Equipment



Being the first. Keeping the lead.

Since introducing Gravel Charlie, the world's first series manufactured articulated hauler, Volvo has consistently led the way when it comes to pioneering technology which delivers unrivalled levels of sustainable productivity and performance.

Today we offer the most comprehensive range of articulated haulers in the industry, with common technology throughout, ensuring optimum results whatever size class you operate. Combined with a range of complementary services and solutions, you can count on Volvo Articulated Haulers to deliver the lowest possible cost per tonne.

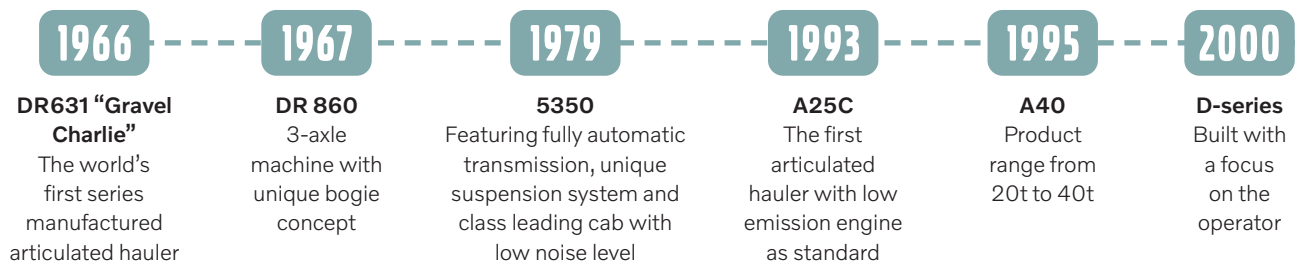



As part of our enduring focus on environmental care we are committed to Science Based Targets to achieve net-zero value chain emissions by 2040. From product planning through to end-of-life, our focus continues to be on minimizing our global footprint and driving transformation in our industry.



Follow our carbon reduction journey

2007

E-series and A40 FS
The world's first full suspension articulated hauler

2011

F-series
Further improving ease of operation and environmental care

2014

G-series
Wet, cooled brakes on all models

2016

A60H
The world's largest articulated hauler

TODAY

A 25t to 55t
product offering, complete with a range of services

Keep on moving

Effective maintenance can have a big influence on your total cost of ownership. Volvo Articulated Haulers are designed to be easy to service, helping you to maximize your uptime and keep maintenance costs to a minimum.

Reduce oil volume by half

When measured over the lifetime of the machine, Volvo Articulated Haulers require less than half the fluid volume compared to competition, benefitting both the environment and your operating costs.



1,000hr engine service intervals

Volvo Engine Oil and High Performance Filters offer 1000 hour engine service intervals. The result is 50% less oil and filters – reducing maintenance requirements as well as your environmental impact.



Easy to service

Servicing your machine is quick and easy thanks to industry leading service access and essential maintenance points accessible from the ground. The front grill swings down, opening a service platform with anti-slip steps and the electric hood opens to 90 degrees, allowing full access to the engine compartment.



Service alerts

Fluid levels are constantly monitored with timely service alerts displayed on the dashboard, helping you stay on top of your maintenance requirements.





Reduce your maintenance costs with Volvo
Articulated Haulers.



NO DAILY OR WEEKLY GREASING

With Volvo Articulated Haulers greasing is only required every 250 hours – the best in the industry – delivering maximum uptime.

Haul Assist

Gain access to a set of tools designed to help you get the most out of your Volvo Articulated Hauler and boost your profitability.

Proactive tire management

Optimize tire life with the support of the Tire Pressure Monitoring System, which allows the operator to monitor tire pressure and temperature from the comfort of the cab.



A complete site overview

Monitor the whereabouts of all your machines, vehicles and visitors in real-time with Map, a connected tool which provides accurate positioning to help monitor on-site traffic and navigate the site more efficiently.



Go into detail

Reports can be generated automatically on a daily and weekly basis, or manually at any time, including the geo-tracking of moved material which is enabled by Map.



Support you can count on

As a fully integrated and factory-fitted Volvo system, all the components, hardware and software of Haul Assist are supported by your Volvo dealer to keep your operation running smoothly. What's more, you will benefit from over-the-air updates, easy upgrades and remote support.





The perfect Assist-ant to help get the most of your Volvo Articulated Haulers.



Watch our Haul Assist video ▶



TAKE CONTROL OF YOUR PRODUCTIVITY

On-Board Weighing provides real-time payload information which can help to eliminate carry-back and overloading; the result is peak productivity, reduced fuel consumption and less machine wear.

Bigger and bolder

With 100% off-road performance, proven Volvo technology and impressive payload, count on the Volvo A60H Articulated Hauler to boost your profits.

Comfort at speed

The A60H is fitted with active hydraulic front suspension – permitting high hauling speeds in tough conditions. This optimizes operator comfort and stability during travel.



Unbeatable off-road performance

The ground-breaking A60H is the best articulated hauler on the market. With matched drivetrain, automatic drive combinations including 100% differential locks, all-terrain bogie and hydro-mechanical steering, this machine is unbeatable.



Articulated hauler concept

Go where others can't. The A60H embodies the full articulated hauler concept and provides total versatility so you can access the entire jobsite and climb steeper gradients. Work in all seasons, terrains and applications using tailored machine configurations and tires, optimized for this 60 tonne machine.





Volvo Articulated Haulers deliver
the highest profitability.



MOVE MORE FOR LESS

Reach your production targets faster and reduce your cost per tonne with the Volvo A60H. The largest articulated hauler on the market offers up to 40% more productivity along with outstanding fuel efficiency.

Control in comfort

The industry-leading cab appeals to operators and helps maintain productivity all day, every day.

Total control

Stay in control at all times. The dump support system, dynamic Volvo engine brake, load and dump brake and hill assist, all help the operator to control the machine for extra productivity and safety.



Ease of operation

The ergonomic, comfortable and easy-to-understand controls are designed to suit all operators, combined with automatic functions for increased ease of operation.



Operator comfort

Feel comfortable and spend more time in the Volvo Articulated Haulers. The centrally positioned operator, superior steering, excellent suspension, low noise levels, climate control, space and visibility reduce operator fatigue for more effective operations.



Safety first

Whether its operators, trainers, technicians or site workers – safety on site is of fundamental importance. In the Volvo Articulated Haulers superior visibility and efficient lighting combine with features such as the brake test and dump support, helping to keep everyone working around the machine safe.





Volvo Articulated Haulers are the operator's number one choice.



OPERATOR'S CHOICE

A happy operator is a more productive operator and when many other machines are onsite, most operators prefer the Volvo. Even in the most adverse conditions, its comfortable cab and ease of operation keep operators alert and performing their best.

Simply the best and the biggest

Only from Volvo

- Proven Volvo engine and matched driveline: high performance, high fuel efficiency
- Automatic drive combinations including 100% differential locks, all-terrain bogie and hydromechanical steering
- Active hydraulic front suspension for high hauling speeds in tough conditions
- The largest articulated hauler on the market, delivering 40% more productivity

The operator's choice

- Ease of operation: ergonomic and easy-to-understand controls
- Centrally positioned operator for best-in-class visibility
- Hill assist, dump support system, load and dump brake
- Built-in brake test: schedule and perform a stationary brake test, guided by the machine display

Solutions for you

- Easy machine monitoring: CareTrack, ActiveCare Direct
- Lifetime Frame and Structure Warranty
- 24hr parts delivery guarantee
- Genuine Volvo Parts
- Volvo Site Simulation: get recommendations on the best fleet configuration and site set-up
- Operator Training Program: unlock the full potential of your machine
- Uptime Services: control your maintenance costs



Haul Assist

- On-Board Weighing: real-time payload monitoring
- Tire Pressure Monitoring System
- Map: real-time positioning of on-site traffic
- Productivity Reports, including the geo-tracking of moved material
- Over-the-air updates, easy upgrades, remote support

Service and maintenance

- 250-hour greasing interval
- Half the fluid volume compared to the competition
- 1,000hr engine service intervals
- Service reminders and fluid level monitoring
- Industry-leading service access and ground-accessible service points



Configured for success

Ensuring your fleet is configured in the correct way can yield huge benefits to your operation including more productivity, enhanced performance and less costs.

Here are some tips to help tailor your new Volvo Articulated Hauler according to the application, site conditions and type of transported material, as well as matching to the appropriate loading unit. For more detailed information, talk to your Volvo dealer!

Body options

Question	Answer	Solution
Dealing with height restrictions? Operating in restricted height conditions e.g. silos or underground	No	Select standard body
	Yes	Select low profile body
Hauling abrasive material? Granite, silicate etc	No	<i>Go to next question</i>
	Yes	Select wear plates / rock liners for extended service life
What material density? Gravel is ~1.4 sh tn/yd ³	> 1.3 sh tn/yd ³ (gravel, blasted rock)	<i>Go to next question</i>
	1.0 - 1.3 sh tn/yd ³ (dry earth, shale)	Select side extensions to increase body volume
	< 0.85 sh tn/yd ³ (coal, fly ash etc)	Select light material kit to increase body volume
Front spill protection needed? Getting loaded by large excavator	No	<i>Go to next question</i>
	Yes	Select front spillguard
Extra load retention needed? Risk of dropping material e.g. when climbing steep inclines	No	<i>Go to next question</i>
	Yes, but not hauling boulders	Select tailgate – overhung type – to reduce spillage
	Yes, hauling boulders	Select tailgate – underhung type – to reduce spillage
Hauling sticky material? Risk of carry-back	No	<i>Go to next question</i>
	Yes	Select body exhaust heating

Exceeding gross machine weight is not permitted.
Payload should be reduced by the weight of the optional equipment.

Tires

Question	Answer	Solution
Operating on abrasive haulroad? Risk of tire cuts or extensive wear	No	E3 tires are optimized for soft ground, offering the best traction and high average speed
	Yes	Select E4 tires for the best cut resistance, comfort and tread life
Extra flotation needed? Risk of sinkage in soft ground	No	Select standard profile tires
	Yes	Select low profile tires, featuring lower ground pressure for improved flotation, stability and comfort

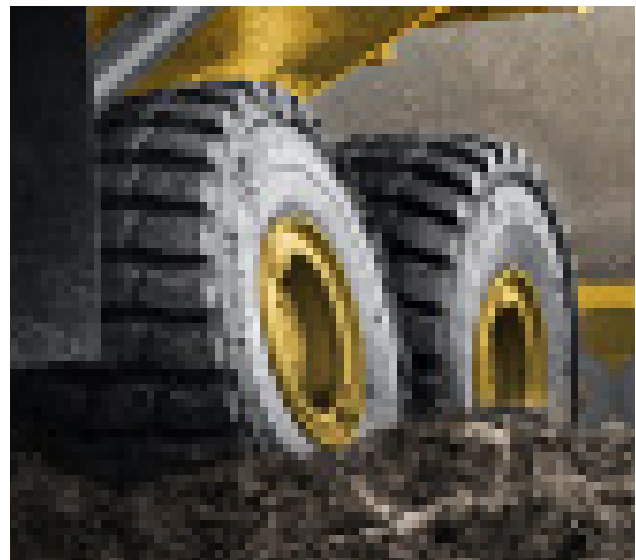

Optimal pass-matching

Volvo Excavator	EC480	EC530	EC550	EC750	EC950
	Number of passes				
A60H	11	9	8	7	5

Excavator overcapacity, 3 buckets or below
Well matched, 4-6 buckets (≈ 90 seconds loading time)
Excavator undercapacity, 7 buckets or more
Excavator undersized for optimum match

Volvo Wheel Loader	L220	L260	L350
	Number of passes		
A60H	6	5	4

Loader overcapacity, 2 buckets or below
Well matched, 2-3 buckets (≈ 90 seconds loading time)
Loader undercapacity, 4 buckets or more
Loader undersized for optimum match. Reach might also be an issue



Hauler chassis solutions

With Special Application Solutions and different chassis options you can tailor Volvo Articulated Haulers to your specific needs.



Volvo A60H in detail

Engine

V-ACT, 16 liter, 6-cylinder straight VGT (Variable Geometry Turbocharged) diesel engine with 4 valves per cylinder, overhead camshaft and electronically controlled unit injectors. It has wet replaceable cylinder liners and replaceable valve guides and valve seats.

The engine has cooled EGR (Exhaust Gas Recirculation) and exhaust after treatment with EAT-Muffler (Exhaust After treatment) including DOC (Diesel Oxidation Catalyst), DPF (Diesel Particulate Filter) and SCR (Selective Catalytic Reduction) with an electronically controlled UDS (Urea Dosing System).

After treatment system features passive DPF regeneration with an AHJ (After treatment Hydro carbon Injection) device as back up.

Engine model	Volvo	D16J
Max power - SAE J1995 Gross	kW (hp)	470 (630)
at engine speed	r/min (r/s)	1,800 (30)
Flywheel power - ISO 9249, SAE J1349 Net	kW (hp)	467 (626)
at engine speed	r/min (r/s)	1,800 (30)
Max torque - SAE J1995 Gross	Nm (ft lbf)	2,960 (2,183)
Max torque - ISO 9249, SAE J1349 Net	Nm (ft lbf)	2,942 (2,170)
at engine speed	r/min (r/s)	1,050 (17.5)
Displacement	l (in ³)	16.1 (982)

Electrical System

All cables, sockets and pins are identified. Cables are enclosed in plastic conduits and secured to main frame. Halogen lights. Prewired for options. Connectors meet IP67 standard for water-proofing as necessary.

Voltage	V	24
Battery	V	2x12
Battery capacity	Ah	2x225
Alternator	kW/A	2.264/80
Starter motor	kW	9

Drivetrain

Torque converter with built-in lock-up function.

Transmission: Fully automatic Allison planetary transmission with 6 forward gears and 2 reverse gears. Internal torsional damper in the torque converter.

Dropbox: Volvo-developed, in-line design with high ground clearance and 100% longitudinal "dog clutch" type differential lock.

Axles: Heavy duty, purpose built Volvo design with fully floating axle shafts, planetary type hub reductions and 100% dog clutch type diff-lock. Automatic traction control system (ATC).

Torque converter		1.85:1
Transmission	Volvo	6630 ORS
Dropbox	Volvo	IL3 ATC
Axles	Volvo	AHW80

Brake system

Fully hydraulic, wet multiple disc brakes with enclosed, forced oil-cooled multiple discs on all wheels. Two circuit brake system. Complies with ISO 3450 at total machine weight.

Circuit division: One circuit for front axle and one for bogie axles.

Parking brake: Spring-applied disc brake on the propeller shaft, designed to hold a loaded machine on a grade of up to 18%. When the parking brake is applied, the longitudinal differential is locked.

Retarder: Service retarder function and Volvo Engine Brake (VEB).

Steering System

Hydro-mechanical articulated steering, self compensating design. Two double-acting steering cylinders.

Rotating hitch: 3,4 steering wheel turns lock-to-lock, $\pm 45^\circ$.

Steering system, including secondary steering fulfills ISO 5010.

Chassis

Frames: box type, heavy duty. High strength steel, robot welded.

Rotating hitch: 100% maintenance free, fully sealed, with permanently greased tapered roller bearings.

Cab

Mounted on rubber pads. Ergonomically designed. Easy entry and exit.

Wide angle forward view.

Operator centrally positioned above the front axle. Adjustable operators seat with retractable seat belt.

Tilt/telescopic steering wheel. Ergonomically positioned controls. Filtered air. Climate control system.

Operator communication system: Contronics.

Large color display, user-friendly and easy-to-understand information, all vital machine functions are constantly monitored.

Instructor seat with seat belt.

Safety: ROPS/FOPS standards approved according to ISO3471, SAE J1040 / ISO3449, SAE J231.

Sound level in cab (ISO 6396) - L _{PA}	dB	72
External sound level (ISO 6395) - L _{WA}	dB	113

Internal sound level with sound kit: 70 dB(A)

External sound level with sound kit: 111 dB(A).



Hydraulic system

Pumps: Five variable displacement piston pumps driven by the flywheel PTO.

One ground-dependent piston pump for secondary steering mounted on the dropbox.

Two return oil filters with magnetic cores provide effective oil filtration.

System max working pressure	MPa (psi)	28 (4,061)
-----------------------------	-----------	------------

Dumping System

Patented Load and Dump Brake.

Dumping Cylinders: two single stage double acting cylinders.

Tipping angle	°	70
---------------	---	----

Tipping time with load	s	13
------------------------	---	----

Lowering time	s	10
---------------	---	----

Body

Plate thickness

Front	mm (in)	8 (0.31)
-------	---------	----------

Sides	mm (in)	14 (0.55)
-------	---------	-----------

Bottom	mm (in)	16 (0.63)
--------	---------	-----------

Chute	mm (in)	16 (0.63)
-------	---------	-----------

Material

Yield strength	N/mm ² (psi)	1,000 (145,038)
----------------	-------------------------	-----------------

Tensile strength	N/mm ² (psi)	1,250 (181,297)
------------------	-------------------------	-----------------

Load Capacity

Standard Body

Load capacity	kg (sh tn)	55,000 (60.6)
---------------	------------	---------------

Body, struck	m ³ (yd ³)	25.8 (33.7)
--------------	-----------------------------------	-------------

Body, heaped 2:1	m ³ (yd ³)	33.6 (43.9)
------------------	-----------------------------------	-------------

With overhung tailgate

Body, struck	m ³ (yd ³)	26.5 (34.7)
--------------	-----------------------------------	-------------

Body, heaped 2:1	m ³ (yd ³)	35.1 (45.9)
------------------	-----------------------------------	-------------

Suspension

Front suspension: Unique, full hydraulic, with automatic leveling and stabilizer.

Rear suspension: 100% maintenance free. Straddle mounted bogie beam. Independent wheel movement via a 3-point mounting system.

Hydraulic cylinders (struts), front/rear	2/0
--	-----

Accumulators, oil-nitrogen, high pressure, front	2
--	---

Levelling sensors	2
-------------------	---



Specifications

REFILL CAPACITIES

Crankcase	l	gal	55	14.5
Fuel tank	l	gal	750	198.1
Cooling system	l	gal	75	19.8
Brake cooling system	l	gal	131	34.6
Transmission	l	gal	58	15.3
Dropbox	l	gal	12	3.2
Axles, front/bogie	l	gal	74/147	19.5/38.8
Hydraulic tank	l	gal	198	52.3
DEF	l	gal	60	15.9

SPEED

Forward				
1	km/h	mph	7	4
2	km/h	mph	10	6
3	km/h	mph	13	8
4	km/h	mph	19	12
5	km/h	mph	26	16
6	km/h	mph	55	34
Reverse				
1	km/h	mph	5	3
2	km/h	mph	8	5

OPERATING WEIGHT UNLOADED

Tires					33.25R29	
Front	kg	lb	22,750	50,155		
Rear	kg	lb	21,000	46,297		
Total	kg	lb	43,750	96,452		
Payload	kg	lb	55,000	121,254		

TOTAL WEIGHT

Tires					33.25R29	
Front	kg	lb	28,900	63,714		
Rear	kg	lb	69,850	153,993		
Total	kg	lb	98,750	217,706		

Operating weight includes all fluids and operator

GROUND PRESSURE

Tires					33.25R29	
Unloaded						
Front	kPa	psi	125		18.1	
Rear	kPa	psi	58		8.4	
Loaded						
Front	kPa	psi	159		23.1	
Rear	kPa	psi	193		28	

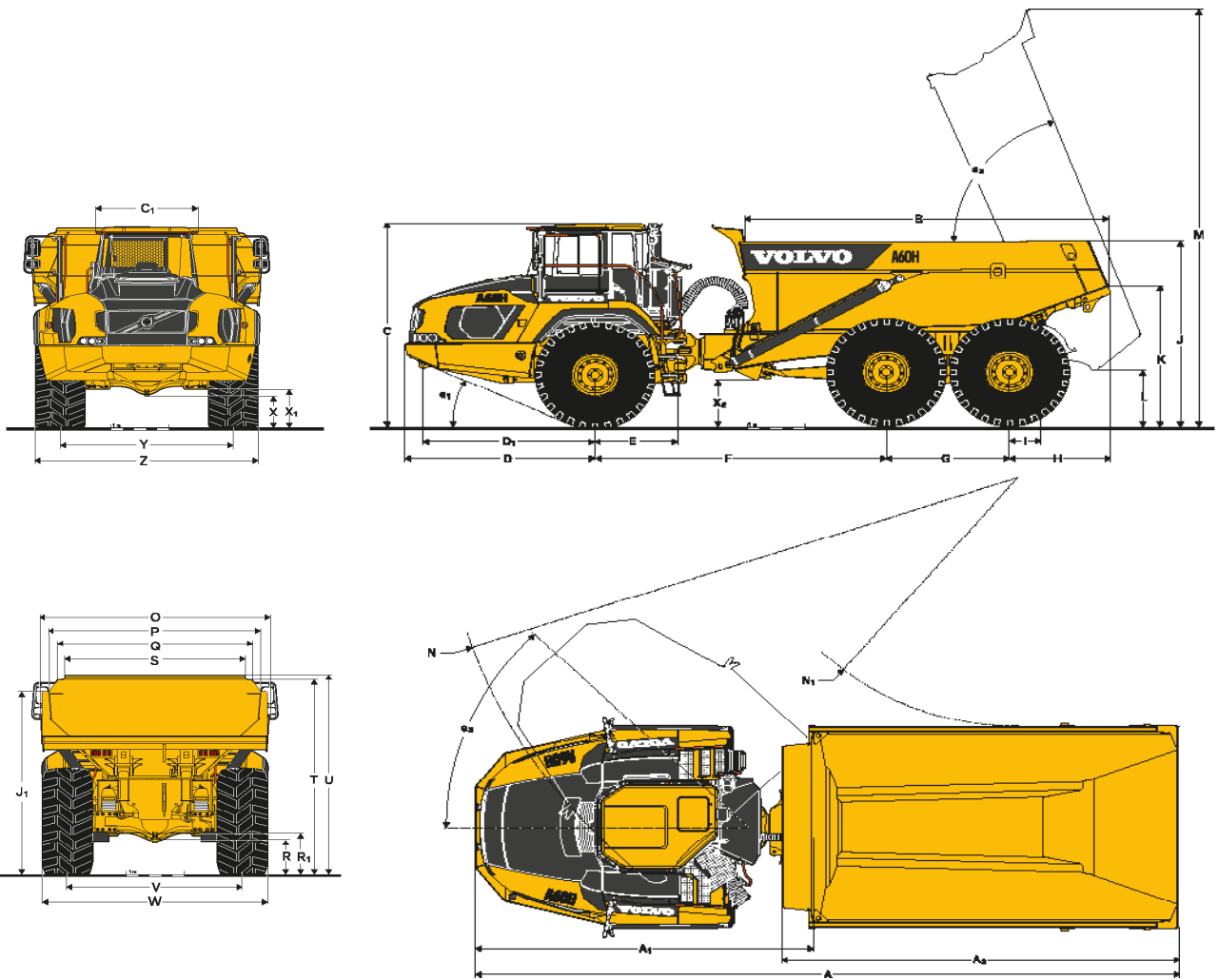

DIMENSIONS

Pos	Unit	A60H	
A	mm ft in	12 225	40'1"
A ₁	mm ft in	5 872	19'3"
A ₂	mm ft in	6 900	22'8"
B	mm ft in	6 310	20'8"
C	mm ft in	3 852	12'8"
C ₁	mm ft in	1 772	5'10"
D	mm ft in	3 293	10'10"
D ₁	mm ft in	2 986	9'10"
E	mm ft in	1 440	4'9"
F	mm ft in	5 050	16'7"
G	mm ft in	2 140	7'0"
H	mm ft in	1 743	5'9"
I	mm ft in	541	1'9"
J	mm ft in	3 510	11'6"
K	mm ft in	2 658	8'9"
L	mm ft in	1 030	3'5"
M	mm ft in	7 960	26'1"
N	mm ft in	10 014	32'10"
N ₁	mm ft in	4 761	15'7"
O	mm ft in	3 989	13'1"

DIMENSIONS

Pos	Unit	A60H	
P	mm ft in	3 673	12'1"
Q	mm ft in	3 370	11'1"
R	mm ft in	677	2'3"
R ₁	mm ft in	778	2'7"
S	mm ft in	3 126	10'3"
T	mm ft in	3 734	12'3"
U	mm ft in	3 833	12'7"
V	mm ft in	3 010	9'11"
W	mm ft in	3 884	12'9"
X	mm ft in	601	1'12"
X ₁	mm ft in	727	2'5"
X ₂	mm ft in	845	2'9"
Y	mm ft in	3 010	9'11"
Z	mm ft in	3 884	12'9"
a ₁	°		24.9
a ₂	°		70
a ₃	°		45

A60H: Unloaded machine with 33.25R29 tires.

Equipment

STANDARD EQUIPMENT

Engine

Direct injected, electronically controlled, turbocharged, intercooled

Grouped oil filters

Preheater for easier cold starts

VEB (exhaust retarder EPG + compression brake)

Tires

33.25R29

800/80R29

Drivetrain

6x4 and 6x6 automatically engaged drive modes

Dog clutch type 100% diff-locks in all axles

Full automatic transmission

Two-stage dropbox with longitudinal diff-lock

Torque converter with automatic lock-up

Electrical System

80 A alternator

Battery disconnect switch

Extra 24 V socket for lunch cooler

Lights:

Back-up light

Brake lights

Cab lighting

Direction indicators

Headlights

Instrument lighting

Parking lights

Rear lights

Brake system

Hill assist

Load & Dump Brake

Retarder pedal

Parking brake on propeller shaft

Two circuit, fully hydraulic, wet discs on all axles

Body

Body prepared for exhaust heating and optional equipment

On board weighing (OBW)

Safety

Anti-slip steps and platforms

Dump body lock

Handrails on steps and platforms

Hazard lights

Horn

Protective grill for cab rear window

Rear-view mirrors

Retractable 3-inch safety belt

ROPS/ FOPS - certified cab

Secondary steering

Steering joint lock

Windshield washers

Windshield wipers with interval function

Dump support system

STANDARD EQUIPMENT

Comfort

ACC control panel

Ashtray

Cab heater with filtered fresh air and defroster

Can holder /storage tray

Instructor seat with seat belt

Overhead console for radio

Sliding window

Space for lunch cooler

Storage box

Sun visor

Tilt/telescopic steering wheel

Tinted glass

Operator information interface

Gauges:

Brake pressure

Fuel

Speedometer

Tachometer

Wet disc brakes cooling oil temperature

Warning lights grouped and easy to read

Central warning (3 levels) for all vital functions

Central positioned information display

Automatic pre-start checks

Clock

Hour meter

Operational information, easy-to-navigate menu

Troubleshooting diagnostics

Exterior

Front mudguard wideners and rear mudflaps

Service and maintenance

Electrical engine hood and belly plate

Drainage hose

Machine Tracking Information System MATRIS

Service platform integrated in the front grill

Tool box

OPTIONAL EQUIPMENT

Engine

Air filter, heavy duty, EON

Engine heater, 240 V

Engine heater, diesel (Eberspächer)

Engine auto shutdown

Engine shutdown timer

External emergency engine stop

High engine idle speed

OPTIONAL EQUIPMENT

Electrical System

- Headlights, LED
- Warning beacon, LED
- Working lights, LED
- Entrance light
- Seat belt indicator, external
- Anti-theft system (pin code)
- Rear view camera
- Reverse alarm
- CAN-BUS interface, extra

Cab

- Noise reduction kit (fulfils 2000/14/EC)
- Anchorage, operator's manual
- Cab heating/ventilation timer
- Cable kit, for cab heater
- HEPA cab air filter
- Bluetooth radio kit
- Rear view mirrors, adjustable, el.heated
- Seat belt XXL, non-retractable
- Sun blinds, side windows
- Universal key
- Air suspended, heated, fully adjustable seat
- Armrest for operator seat
- Headrest for operator seat
- Air blow gun

OPTIONAL EQUIPMENT

Body

- Body exhaust heating
- Front spillguard, extra
- Side extension, light material
- Tailgate, overhung, wire-operated
- Wear plates

Safety

- Fire suppression system
- Warning triangle
- First aid kit and fire extinguisher
- Fire extinguisher
- Wheel chocks

Service and maintenance

- Lube system, standard machine
- Tool kit

Others

- Arctic oil kit
- CareTrack
- Fast fuelling system
- Jump start connector, NATO -type
- Haul Assist - Tire Pressure Monitoring System
- Hauler chassi (without body)

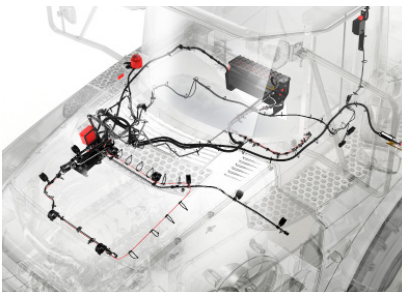
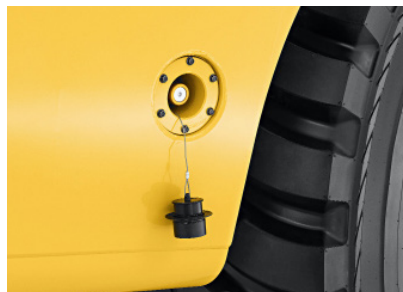
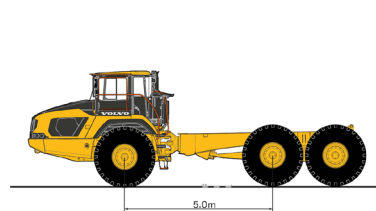
SELECTION OF VOLVO OPTIONAL EQUIPMENT**Fire suppression system****Fast fuelling****Auto lube****Wheel chocks****Hauler chassi****Wear plates**

Not all products are available in all markets. Under our policy of continuous improvement, we reserve the right to change specifications and design without prior notice. The illustrations do not necessarily show the standard version of the machine.

Solutions for you

Our industry leading machines are just the start of your relationship with Volvo. As your partner, we have developed an extensive range of additional solutions to help you improve uptime, boost productivity and reduce costs.

Our portfolio of products and services is designed to complement your machine's performance and boost your profitability. Simply put, we offer some of the best guarantees, warranties and technological solutions in the industry today. Below are just some examples. Talk to your dealer to find out and discuss the right fit for you!

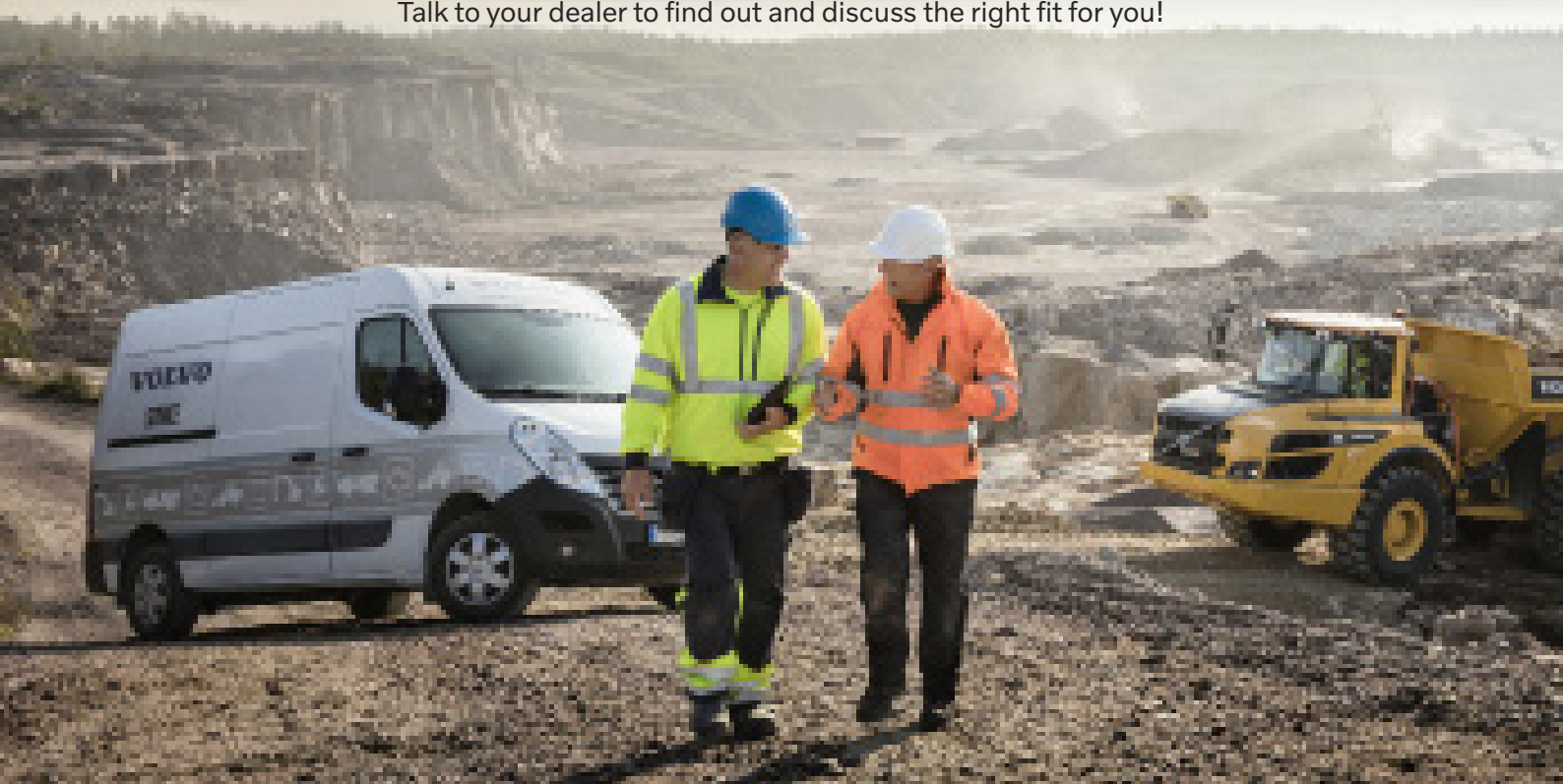

Get the most from your machine

While reliable and efficient machines of course play a vital role in reducing costs, enhancing safety and maximizing productivity, it is ultimately the performance of the operator that really makes the difference. We offer a range of training initiatives to help operators unlock the full capability of their Volvo Articulated Hauler.

Connected to Uptime

Maximize machine uptime and reduce repair costs with the CareTrack telematic system. Choose to keep track of your machine yourself or let us take care of it with ActiveCare Direct. Our Volvo Uptime Center will provide 24/7 machine monitoring, supplying weekly reports and notifying you should preventive maintenance action be required.

Control your maintenance costs

Stay on track with planned servicing and keep your asset covered with our range of flexible maintenance and repair agreements.



Fuel Efficiency Services



Productivity Services



Safety Services



Financial Services



Uptime Services



Rental Services



Volvo Attachments



Genuine Volvo Parts



New Life Services

Optimize site efficiency

Using Volvo Site Simulation, we can help you make on-site logistics more efficient and lower your cost per tonne. Get recommendations on the best fleet configuration and site set-up to maximize profitability.

24h parts delivery guarantee

Maintain productivity and machine uptime with our range of readily available parts, all backed by Volvo warranty – with 24-hour parts delivery guarantee. Only by using Genuine Volvo Parts, can you protect your investment, extend machine life and guarantee long lasting performance.

Lifetime Frame and Structure Warranty

Quality has long been a hallmark of the Volvo brand. Decades of experience, both in the field and in the laboratory, are today delivering unsurpassed frame and structure durability. We believe in the quality of our products – so much so that Volvo machines come with a Lifetime Frame and Structure Warranty, covering the frame, articulation joint.

V O L V O